

X-PRESS INSTRUCTIONS

Limited 2-Year Warranty

PARTS ENCLOSED

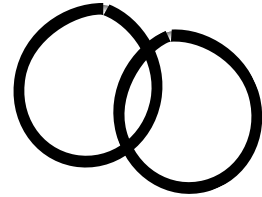

(2) Stretchable Rubber Straps

A

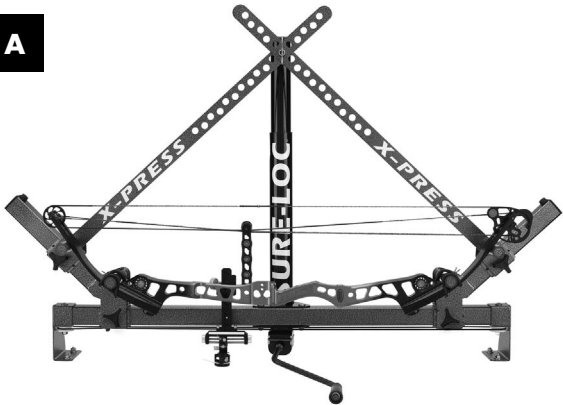

B

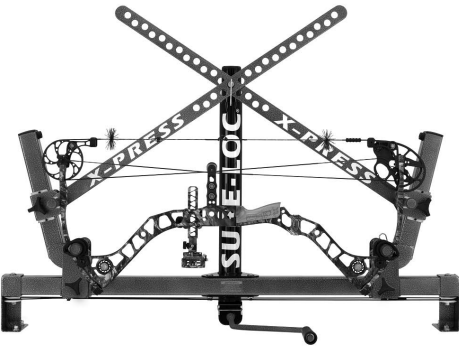

C

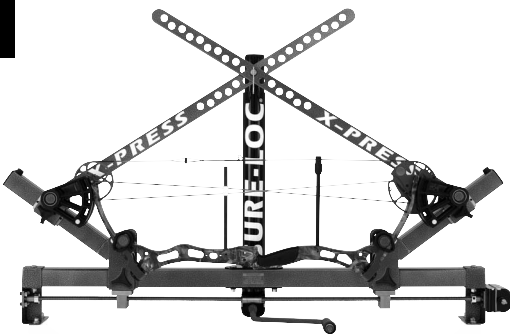

D



"4-IN-ONE" PRESS

Press all bows safely, quickly and with ease!

- A** • Conventional Limb Angle
- B** • Parallel Limb Technology
- C** • Ultra-Short Limb Bows – see back page
- D** • Crossbows

Booklet Contents:

- Pg 2 • Important jack information
- Pg 2 • X-PRESS Assembly
- Pg 2 • Using the X-PRESS
- Pg 3 • X-PRESS diagram
- Pg 4 • Important maintenance and care instructions
- Pg 4 • USL kits
- Pg 4 • Press stand assembly
- Pg 4 • Tray installation
- Pg 4 • Serving jig

Detailed instruction movie also on DVD!

C.S. Gibbs Corporation

100 W. Quality Lane
Versailles, IN 47042

(812) 689-9926 phone
(812) 689-9927 fax

www.sureloc.com

X-PRESS ASSEMBLY

1. Remove all contents from boxes: press; mounting hardware: carriage bolts (2), flat and lock washers, nuts; riser support unit knobs (2); rubber straps (2); hairpin clip; jack; crank handle; instruction booklet; instruction DVD (assembly, operation, maintenance)

2. Install jack on horizontal main tube:

- Disassemble mounting hardware.
- Align holes of jack bracket with holes of main frame.
- Matching the square hole with the square of the carriage bolt, install washer and lock washer and nut onto bolt. Tighten nut to secure the jack to the main frame.

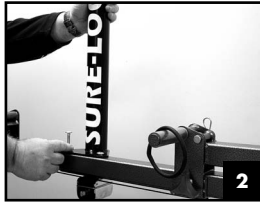

3. Unfasten the nuts and bolts from the shipping board and remove X-PRESS by lifting the main frame.

Note: If the timing cable under the X-PRESS (not PRO model) horizontal main tube has come loose during shipping, follow these steps to tighten the cable and time the riser supports:

- a• Loosen the riser support unit knobs and slide the pin units to the center jack mounting plate.
- b• Tighten riser support unit knobs.
- c• Loosen the timing cable clamp that has the cable continuing through it.
- d• Loosen the timing cable clamp where the knotted cable is located.
- e• Pull the knotted ends of the cable until the cable is tight and tighten the screws of this cable clamp.
- f• Tighten the screws of the other cable clamp.

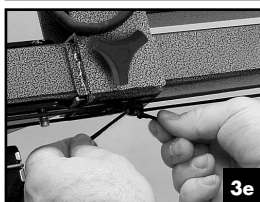

4. Mount X-PRESS on bow press stand or bench.
5. Remove both upper pin bracket knobs and swing the X-straps around and onto the jack post.
6. Install hairpin clip in the jack pin hole and reinstall the pin bracket knobs.
7. Remove the 5/16 bolts (used only for shipping purposes) from the front of the riser support units and install the riser support unit knobs from the hardware package.

USING THE X-PRESS

1. Set jack height.

Proper jack height is required to ensure that no damage is done to the bow or press. Set the jack ram to a height so that the X-straps—when placed on the jack pin—are square to the bow limbs at the point the 7/8" limb support pins contact the bow limbs. This will minimize the chance of the limb supports sliding up the limbs and into the cams. Also, ensure that the selected holes of both X-braces match each other.

Remember that the jack height and X-straps need to be set to match the direction the limbs flex when drawn.—

This does two things: it allows the limbs to be flexed the way the bow is drawn and it gives you enough room to let your bow completely down for limb changes, etc.

A Conventional bows

Start with the jack set at about 4-6" from the bottom of its travel.

B Parallel limb technology

For the more recent parallel limb bows, the X-PRESS jack does not always go low enough to follow the instructions in Step 1A. It will still press these bows efficiently, as long as you minimize the jack height for the type of work to be performed:

- If you require string work or cam maintenance, start with the jack about 1" up from the bottom of jack travel.
- If you need to fully relax the bow so it can be removed from the press for disassembly, limb removal, etc., start with the jack approximately 6" up from the bottom. Typically this is enough travel to relax most bows.

C Ultra-short & past-parallel limb bows

For these bows ONLY, please use one of the SURE-LOC® USL Kits (shown on page 4) to allow for proper pressing. USL Kits not needed to press Mathews bows. See instructions included with kits.

D Crossbows

Method 1: Remove the stock assembly from limb bezel assembly and press the limb bezel assembly in the X-Press by itself, like a standard bow. Then you won't need to deal with the awkward mass and weight of the stock. Adhere to the above instructions for press setup stated in Step 1A.

Method 2: Put the crossbow in the X-PRESS with the trigger guard facing outward from the press jack. Then raise the jack as to allow the X-straps to clear the sight or scope of the crossbow. This will give you clearance to do your work or maintenance. **CONT >**

IMPORTANT JACK INFORMATION

Do not try to force the jack against the upper or lower limits of the jack ram. This could cause damage to the gear drive parts.

Excessive use of the jack at or above 11 inches—measured from the jack pin to the top of the outer jack housing—can cause galling on the mating surfaces of the inner jack ram and outer tube resulting in jack lock-up.

When more than half of the jack ram is above the jack's outer tube, the pressures against the tube's mating surfaces are increased significantly. This also exceeds the recommended set-up height of most bows, excluding crossbows. So, typically the jack should not need to be that high anyway. If you see any wear on jack surfaces, follow maintenance instructions.

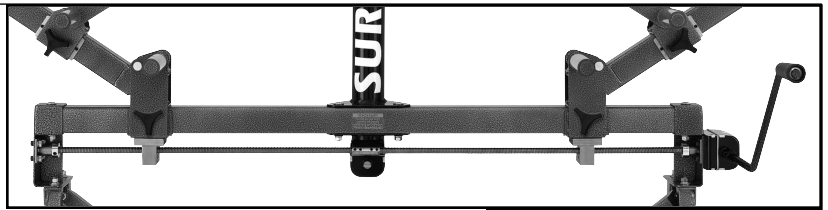

X-PRESS PRO

with gear-driven riser support adjustment & side crank control

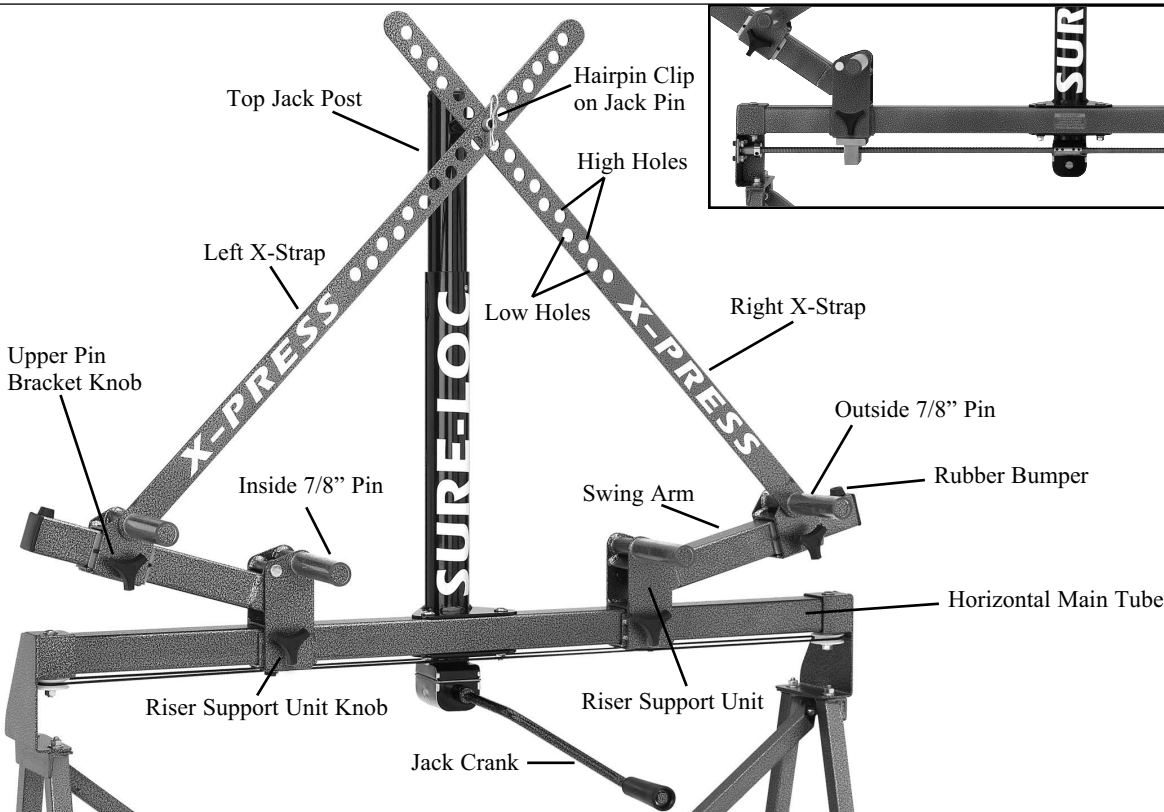

2. Loosen knobs on upper pin bracket and slide the bracket out to the rubber bumpers. Leave the X-straps attached to the jack pin.

3. Loosen the two front knobs of the riser support units and slide/crank the pin units in or out so that the two inside 7/8" pins are close to where the bow riser and the bow limb meet.

Tip for the X-PRESS (not PRO): Place your thumbs at the base of each riser support bracket—just above the main horizontal tube—and 2 forefingers on the outside of the riser support bracket. While sliding out on the bracket, press down and outward with your thumbs and upwards with your fingers—the supports will slide easier.

4. Set the press for the length of the riser: Place the bow riser or limb on top of the inside 7/8" pins with the bow string down and slide/crank the pin units until they rest in the pocket where the riser and the limbs meet. Lock the front riser support unit knobs.

Note: Make sure that the rubber straps are on the inside 7/8" pins toward the press arms before continuing.

5. Remove hairpin clip from the jack pin.

6. Remove the X-straps from the jack post and rest them on the inside 7/8" pins.

7. Remove the bow and turn it over with the string side up and set it under the inside 7/8" pins so they sit in the pocket where the riser and limbs meet. Pull the rubber straps under the limb

and over the pin.—This will support the bow and free up your hands to make it easier to continue.

8. With one hand pull one of the X-straps up. With the other hand loosen the side knob. While holding the X-strap/bracket assembly to the limb, slide the outside 7/8" pin bracket so the pin rests just below the cams, making sure you leave enough room to work on the cams.

Tip: Some bows may have to be set just above or below the limb buttons. If there are limb savers on the bow, the 7/8" pin may be placed between them and the cam. In some cases the limb saver may need to be moved a little bit to position the X-strap pins the same on both limbs.

9. Slide the other end of this X-strap onto the jack pin to the nearest hole, while keeping the outside 7/8" pin as close as possible to the limb.

10. Repeat steps 8 and 9 for the other X-strap and 7/8" pin alignment.

Tip: Notice which hole (high or low) the first X-strap is in and use the same for the second X-strap (high hole with high hole or low hole with low hole). This should eliminate the counting of the holes and make setup easier.

Note: The hole count **has** to match on both sides.

11. Reinsert the hairpin clip. Now you are ready to crank the jack up to relax the bowstring.

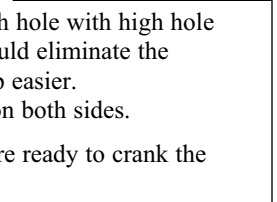
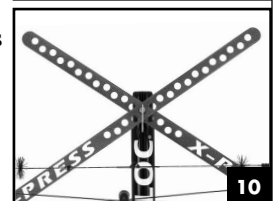
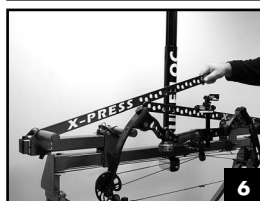
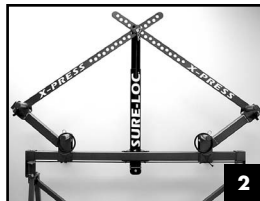

JACK MAINTENANCE

Supplies/tools required: clean cloth, silicon base lubricant, file or fine grit sandpaper, 1/2" wrench, 5/32" punch, hammer)

To keep the X-PRESS working properly, extend the jack shaft fully and wipe the inner tube down with a silicone base lubricant at least **monthly**.

At least once per year—and when surfaces show wear—the jack should be disassembled for inspection and maintenance.

Disassembly and Maintenance:

1. Raise jack approximately 4" to 6" and then detach it from the horizontal main tube of the X-PRESS.
2. Remove jack shield clip from bottom of jack and slide the jack shield off to expose the gears.
3. Drive out the roll pin in the small gear using a 5/32" punch. Slide the jack's crankshaft out and remove both gears. Then take out the drive screw pin.
4. Separate the inner tube from the outer jack sleeve, by tipping the upper end of the jack down and gently sliding the two halves apart. Remove and set aside the thrust washer and bearing on the end of the drive screw.
5. Inspect the ends of the inner tube and outer jack sleeve for burrs. Use fine grit sandpaper or a file to smooth any rough edges on the tube ends.
6. Wipe old grease and lubricant from tube and sleeve with a clean cloth. Lubricate the tube mating surfaces with a lithium-based grease. Also clean and lubricate the jack's drive screw.

Reassembly:

1. Point the top end of jack threaded rod up and install the thrust washer and bearing on the end of the drive screw.
2. Slide the outer sleeve over the drive screw, positioning the tube slot in line with the detent in the outer jack sleeve.
3. Install the drive screw pin and slide the large gear over the end of the drive screw, aligning the pin with the slot in the back of the gear.
4. Slide the crankshaft half way in and install the small gear with the teeth facing the large gear. Carefully slide the crankshaft the rest of the way in. Align the pin bore with the slot in the gear and gently drive the roll pin back into the shaft.
5. Lubricate the gears; then reinstall the jack shield and jack shield clip.
6. Remount jack assembly on the X-PRESS.

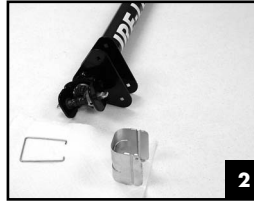

X-PRESS MAINTENANCE AND CARE

Waxing (i.e. car wax) the horizontal main tube will aid in the adjustment of the riser supports.

DO NOT wax the swing arms or limb support brackets. Wipe these parts with an oil-free cleaner.

DO NOT try to force the jack against the upper or lower limits of the jack ram. This could cause damage to the gear drive parts.

USL KITS

The USL kits are easy-to-install accessories—saving you time and money.

KIT 1: Ultra-short limb bows

KIT 2: Ultra-short limb Bowtech bows with center pivoting limbs

Caution: Use of the USL Kits may cause damage to other bows. USL Kits not needed to press Mathews bows. Call us for specific applications or with any questions.

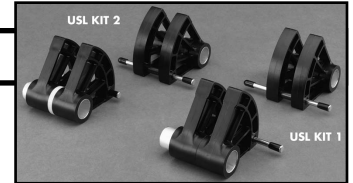

BOW PRESS STAND

1. Place the (2) cross braces together with the beveled sides facing out.
2. Install (1) flat washer and the 2-3/4" long bolt through the first brace, then through the second brace. Install (1) flat washer and the nut.
3. Open the cross brace.
(**Note:** The nuts are welded into the brace ends.) One end of the brace will have a red dot. Match that red dot to the red dot on the A frame to start assembly of the brace and the A frames.
Note: Do not tighten at this time.
4. Insert (1) 5/16" bolt and (1) lock washer into the tab with the red dot on the A frame and screw into tab with red dot of the cross brace.
5. Repeat Step 4 on the rest of the brace and A frame assemblies.
6. Install the (4) leveling footpads into the threaded holes on the bottom of the leg assemblies.
7. Place the bow press on top of the (4) studs.
8. Install (1) washer, (1) lock washer, and (1) nut on each stud.
9. Tighten all fasteners.

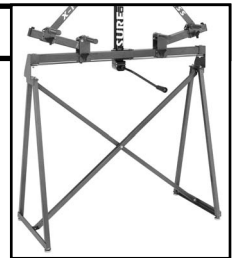

TRAY INSTALLATION

Loosen the nuts that attach the X-PRESS to the bow press stand. Lift the press and slide the tray over the studs. Lower the bow press down on the studs and on the tray. Reinstall nuts and tighten.



SERVING JIG

Lets you re-serve ends without removing strings or cables!

